



ISO 9001
CE



Oil Burner Controls

LMO14...
LMO24...
LMO44...

Microcontroller-based oil burner controls for the startup, supervision and control of forced draft oil burners in intermittent operation. Standard versions with an oil throughput up to 30 kg / h, special versions above 30 kg / h.

The LMO14..., LMO24..., LMO44... and this Data Sheet are intended for use by OEMs which integrate the burner controls in their products.

Use, features

Use	<p>The LMO... are designed for the startup and supervision of 1- or 2-stage forced draft oil burners in intermittent operation. Yellow-burning flames are supervised with photoresistive detectors QRB..., blue-burning flames with blue-flame detectors QRC...</p> <p>In terms of housing dimensions, electrical connections and flame detectors, the LMO... are identical with the LOA... oil burner controls.</p> <ul style="list-style-type: none"> - Oil burners with fans to EN 267 - Burner controls for use with atomization oil burners of monoblock design to EN 230 - LMO44... for use with stationary direct-fired air heaters
General features	<ul style="list-style-type: none"> - Undervoltage detection - Electrical remote reset - Bridging contact for oil preheater - Monitoring of time for oil preheater - Accurate and reproducible control sequence thanks to digital signal handling - Controlled intermittent operation after 24 hours of continuous operation - Limitation of the number of repetitions - Multicolor indication of fault status and operational status messages

Warning notes



To avoid injury to persons, damage to property or the environment, the following warning notes should be observed!

Do not open, interfere with or modify the unit!

- Before performing any wiring changes in the connection area of the LMO..., completely isolate the burner control from the mains supply (all-polar disconnection)
- Ensure protection against electric shock hazard by providing adequate protection for the burner control's connection terminals
- Check to ensure that wiring is in an orderly state
- Press the lockout reset button / operation button only manually (applying a force of no more than 10 N), without using any tools or pointed objects
- Fall or shock can adversely affect the safety functions. Such units may not be put into operation, even if they do not exhibit any damage
- When replacing LOA26... or LOA36..., any remote lockout reset module ARK21... or similar modules fitted in the burner or boiler must be removed



Mounting notes

- Ensure that the relevant national safety regulations are complied with

Installation notes

- Installation work must be carried out by qualified staff
- Always run the high-voltage ignition cables separately while observing the greatest possible distances to the unit and to other cables
- Install switches, fuses, earthing, etc., in compliance with local regulations
- Ensure that the maximum permissible amperages will not be exceeded (refer to «Technical data»)
- Do not feed external mains voltage to the control outputs of the unit. When testing the components controlled by the burner control (fuel valves, etc.), the LMO... may never be plugged in
- Do not mix up live and neutral conductors

Electrical connection of the flame detectors

It is important to achieve practically disturbance- and loss-free signal transmission:

- Never run the detector cable together with other cables
 - Line capacitance reduces the magnitude of the flame signal
 - Use a separate cable
- Observe the maximum permissible lengths of the detector cables (refer to «Technical data»)

Commissioning notes

- Commissioning work must be carried out by qualified staff
- Prior to commissioning the plant, check to ensure that wiring is in an orderly state
- When commissioning the plant or when doing maintenance work, make the following safety checks:

	Safety check	Anticipated response
a)	Burner startup with flame detector darkened	Lockout at the end of «TSA»
b)	Burner startup with flame detector exposed to extraneous light	Lockout after no more than 40 seconds
c)	Burner operation with simulated loss of flame; for that purpose, darken the flame detector during operation and maintain that state	Repetition followed by lockout at the end of «TSA»

Norms and certificates



Conformity to EEC directives

- Electromagnetic compatibility EMC (immunity)
- Low-voltage directive

89 / 336 EEC
73 / 23 EEC



ISO 9001: 2000
Cert. 00739



ISO 14001: 1996
Cert. 38233



Service notes

- Maintenance work must be carried out by qualified staff
- Each time a unit has been replaced, check to ensure that wiring is in an orderly state and make the safety checks as described in «Commissioning notes»
- Use the service adapters KF8885 / KF8833 / KF8840 only for short periods of time

Disposal notes



The unit contains electrical and electronic components and may not be disposed of together with household waste.

Local and currently valid legislation must be observed.

Mechanical design

The housing is made of impact-proof, heat-resistant and flame-retarding plastic. It is of plug-in design and engages audibly in the base.

The housing accommodates the

- microcontroller for the control sequence and the control relays for load control
- electronic flame signal amplifier
- lockout reset button with its integrated 3-color signal lamp (LED) for operational status and fault status messages and the socket for connecting the interface adapter OCI400

Indication and diagnosis

- Multicolor indication of operational status and fault status messages
- Transmission of operational status and fault status messages and detailed service information via additional interface adapter OCI400 and PC Windows software ACS400

Type summary

Type reference	Mains voltage	Fuel valve stages	Burner capacity	1)	Remote reset	Times						Comparable type of LOA...
						tw max.	t1 / t1' min.	TSA-max.	t3 min.	t3n max.	t4 min.	
Standard versions												
LMO14.111B2	AC 230 V	1	< 30 kg / h	•	•	5 s	15 / 16 s	10 s	15 s	10 s	---	LOA24.171B27 LOA26.171B27 ²⁾ LOA36.171A27 ²⁾
LMO14.111B1	AC 110 V	1	< 30 kg / h	•	•	5 s	15 / 16 s	10 s	15 s	10 s	---	LOA24.171B17
LMO14.113B2	AC 230 V	1	< 30 kg / h	•	•	5 s	15 / 16 s	10 s	15 s	3 s	---	LOA24.173A27 ³⁾
LMO24.111B2	AC 230 V	2	< 30 kg / h	•	•	5 s	15 / 16 s	10 s	15 s	10 s	15 s	LOA24.171B27 LOA26.171B27 ²⁾ LOA36.171A27 ²⁾
LMO24.111B1	AC 110 V	2	< 30 kg / h	•	•	5 s	15 / 16 s	10 s	15 s	10 s	15 s	LOA24.171B17
LMO24.113B2	AC 230 V	2	< 30 kg / h	•	•	5 s	15 / 16 s	10 s	15 s	3 s	15 s	LOA24.173A27 ³⁾
LMO24.255B2	AC 230 V	2	</> 30 kg/h	•	•	5 s	25 / 26 s	5 s	25 s	5 s	15 s	---
Version for flash-steam generators												
LMO24.011B2	AC 230 V	2	< 30 kg / h	•	•	5 s	5 / 6 s	10 s	5 s	10 s	15 s	LOA24.571C27
Suited for direct-fired air heaters												
LMO44.255B2	AC 230 V	2	</> 30kg / h	•	•	5 s	25 / 26 s	5 s	25 s	5 s	5 s	LOA44.252A27

Legend

TSAmax.	Maximum ignition safety time
tw	Waiting time
t1	Prepurge time
t1'	Purge time
t3	Preignition time
t3n	Postignition time
t4	Interval from flame signal to release of «BV2»
1)	Bridging contact for oil preheater
2)	No «SA» function
3)	In case of replacement, ignition transformer must be rewired from terminal 7 (LOA...) to terminal 6 (LMO...)

Oil burner control (without plug-in base) refer to «Type summary»

Electrical connections refer to Data Sheet 7201

- Plug-in base AGK11...
- Cable holders AGK65..., AGK66, AGK67...
- Cable strain relief elements for AGK67...

Electrical connections refer to Data Sheet 7203

- Plug-in base AGK13...
- Plug-in housing AGK56...
- Cover AGK68...

Flame detectors

- Photoresistive detectors QRB1... refer to Data Sheet 7714
- Blue-flame detectors QRC1... refer to Data Sheet 7716

Diagnostic tool refer to Data Sheet 7614

- Interface adapter OCI400
- PC Windows software ACS400

Demo case **KF8891**

- For demonstrating the functions of burner controls (refer to User Manual B7989)

Test case **KF8843**

- For checking the functions of burner controls (refer to Operating Instructions C7981)

Test adapter **KF8885**

- For checking the functions of burner controls on the burner
- With switch for manual startup of the burner
- With switch for simulating the oil preheater's release contact
- With 2 pairs of jacks for measuring the flame detector current (refer to Operating Instructions B7986)



Test adapter **KF8833**

- For checking the functions of burner controls on the burner
- With signal lamps for program indication
- With one pair of jacks for measuring the flame detector current



Test adapter **KF8840**

- For checking the functions of burner controls on the burner
- With signal lamps for program indication
- With on / off switch for simulating the flame signal
- With holes for checking the control voltages at the tabs of the burner control
- With one pair of jacks for measuring the flame detector's resistance



Extension of lockout reset button

- Extension 19 mm **AGK20.19**
- Extension 43 mm **AGK20.43**
- Extension 55 mm **AGK20.55**

Technical data

General unit data	Mains voltage	AC 230 V +10 % / -15 % AC 110 V +10 % / -15 %
	Mains frequency	50...60 Hz ±6 %
	External primary fuse (Si)	6.3 A (slow)
	Power consumption	12 VA
	Mounting orientation	optional
	Weight	approx. 200 g
	Safety class	I
	Degree of protection	IP 40 (to be ensured through mounting)
	Perm. cable lengths	max. 3 m at a line capacitance of 100 pF/m
	Detector cable laid separately	20 m
	Remote reset laid separately	20 m

Max. perm. current at $\cos \varphi \geq 0.6$	LMO14...	LMO24... / LMO44...
Terminal 1	5 A	5 A
Terminals 3 and 8	3 A	5 A
Terminals 4, 5, 6 and 10	1 A	1 A

Environmental conditions	Transport	DIN EN 60 721-3-2
	Climatic conditions	class 2K2
	Mechanical conditions	class 2M2
	Temperature range	-30...+70 °C
	Humidity	< 95 % r.h.
	Operation	DIN EN 60 721-3-3
	Climatic conditions	class 3K5
	Mechanical conditions	class 3M2
	Temperature range	
	- LMO14... / LMO24...	-5...+60 °C
	- LMO44...	-20...+60 °C
	Humidity	< 95 % r.h.



Condensation, formation of ice and ingress of water are not permitted!

Flame supervision with QRB... or QRC...

	Min. detector current required (with flame)	Max. perm. detector current (without flame)	Max. possible detector current with flame (typically)
QRB...	45 µA	5.5 µA	100 µA
QRC...	70 µA	5.5 µA	100 µA

The values given in the table above only apply under the following conditions:

- Mains voltage AC 230 V
- Ambient temperature 23 °C

Green LED for operational status indication

	Detector current in operation: - Flame signal instable - Green LED flashing	Detector current in operation: - Flame signal stable - Green LED steady on
QRB...	< 45 µA	> 45 µA
QRC...	< 45 µA	> 45 µA

The values given in the table above only apply under the following conditions:

- Mains voltage AC 230 V
- Ambient temperature 23 °C

Measuring circuit
for detector current

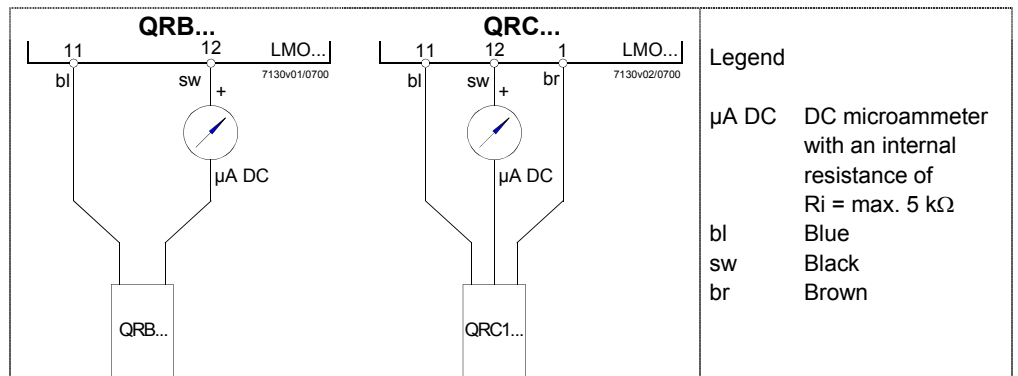

As an alternative to detector current measurement, the diagnostic tool OCI400 / ACS400 can be used. In that case, the DC microammeter is not required.

Function

Preconditions for startup	<ul style="list-style-type: none"> • Burner control is reset • All contacts in the line are closed and there is demand for heat • No undervoltage • Flame detector is darkened and there is no extraneous light
Undervoltage	<ul style="list-style-type: none"> • Safety shutdown from the operating position takes place should mains voltage drop below about AC 165 V (U_N = AC 230 V) • Restart is initiated when mains voltage exceeds about AC 175 V (U_N = AC 230 V)
Time supervision oil preheater	If the oil preheater's release contact does not close within 10 minutes, the burner control will initiate lockout.
Controlled intermittent operation	After no more than 24 hours of continuous operation, the burner control will initiate automatic controlled shutdown followed by a restart.
Control sequence in the event of fault	If lockout occurs, the outputs for the fuel valves, the burner motor and the ignition equipment will immediately be deactivated (< 1 second).

Cause	Response
Mains failure	Restart
Voltage has fallen below the undervoltage threshold	Restart
Extraneous light during «t1»	Lockout at the end of «t1»
Extraneous light during «tw»	Prevention of startup, lockout after 40 seconds at the latest
No flame at the end of «TSA»	Lockout at the end of «TSA»
Loss of flame during operation	Max. 3 repetitions, followed by lockout
Oil preheater's release contact does not close within 10 minutes	Lockout

In the event of lockout, the LMO... remains locked and the red signal lamp (LED) will light up. The burner control can immediately be reset. This state is also maintained in the case of mains failure.

Resetting the burner control	<p>When lockout occurs, the burner control can immediately be reset. To do this, press the lockout reset button for about 1 second (< 3 seconds). The LMO... can only be reset when all contacts in the line are closed and when there is no undervoltage.</p>
Ignition program with LMO14.113B2 and LMO24.113B2	<p>If the flame is lost during «TSA», the burner will be reignited, but only until the end of «TSA_{max}». This means that several ignition attempts can be made during «TSA» (refer to «Control sequence»).</p>
Limitation of repetitions	<p>If the flame is lost during operation, a maximum of 3 repetitions can be made. If the flame is lost for the fourth time during operation, the burner will initiate lockout. The repetition count is restarted each time controlled switching on by «R-W-SB» takes place.</p>

Operation

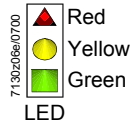
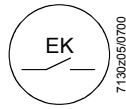

Lockout reset button «EK...» is the key operating element for resetting the burner control and for activating / deactivating the diagnostic functions.

The multicolor signal lamp (LED) in the lockout reset button is the key indicating element for both visual diagnostics and interface diagnostics.

Both «EK...» and LED are located under the transparent cover of the lockout reset button.

There are 2 diagnostic choices:

1. Visual diagnostics: Operational status indication or diagnostics of the cause of fault.
2. Interface diagnostics: With the help of the interface adapter OCI400 and PC software ACS400 or flue gas analyzers of different makes (refer to Data Sheet 7614).

Visual diagnostics:

In normal operation, the different operational statuses are indicated in the form of color codes according to the color code table given below. Interface diagnostics is activated by pressing the lockout reset button for at least 3 seconds (refer to Data Sheet 7614). If, by accident, interface diagnostics has been activated, in which case the slightly red light of the signal lamp flickers, it can be deactivated by pressing again the lockout reset button for at least 3 seconds. The instant of switching over is indicated by a yellow light pulse.

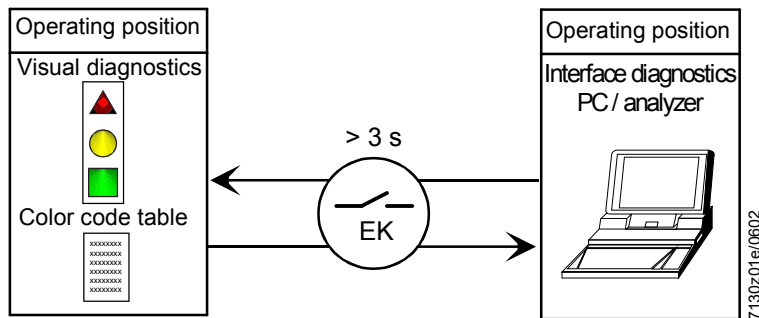

Operational status indication

During startup, status indication takes place according to the following table:

Color code table for multicolor signal lamp (LED)		
Status	Color code	Color
Waiting time «tw», other waiting states	○.....	Off
Oil preheater on, waiting time «tw»	●.....	Yellow
Ignition phase, ignition controlled	● ○ ● ○ ● ○ ● ○ ● ○	Flashing yellow
Operation, flame o.k.	□.....	Green
Operation, flame not o.k.	□ ○ □ ○ □ ○ □ ○ □ ○	Flashing green
Extraneous light on burner startup	□ ▲ □ ▲ □ ▲ □ ▲ □ ▲	Green-red
Undervoltage	● ▲ ● ▲ ● ▲ ● ▲ ● ▲	Yellow-red
Fault, alarm	▲.....	Red
Error code output (refer to «Error code table»)	▲ ○ ▲ ○ ▲ ○ ▲ ○	Flashing red
Interface diagnostics	▲ ▲ ▲ ▲ ▲ ▲ ▲ ▲	Red flicker light

Legend

- Steady on
- Off
- ▲ Red
- Yellow
- Green

Diagnostics of the cause of fault

After lockout, the red fault signal lamp remains steady on. In that condition, the visual diagnostics of the cause of fault according to the error code table can be activated by pressing the lockout reset button for more than 3 seconds. Pressing the reset button again for at least 3 seconds, the interface diagnostics will be activated (for more detailed information, refer to Data Sheet 7614).

The following sequence activates the diagnostics of the cause of fault:

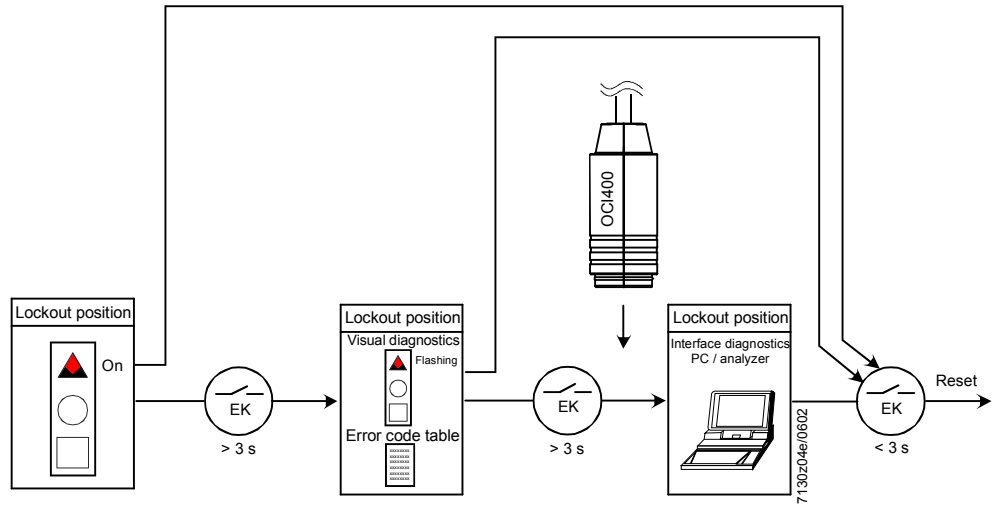

Error code table		
Red blink code of signal lamp (LED)	«AL» at term. 10	Possible cause
2 blinks • •	On	No establishment of flame at the end of «TSA» - Faulty or soiled fuel valves - Faulty or soiled flame detector - Poor adjustment of burner, no fuel - Faulty ignition equipment
3 blinks • • •	On	Free
4 blinks • • • •	On	Extraneous light on burner startup
5 blinks • • • • •	On	Free
6 blinks • • • • • •	On	Free
7 blinks • • • • • • •	On	Too many losses of flame during operation (limitation of the number of repetitions) - Faulty or soiled fuel valves - Faulty or soiled flame detector - Poor adjustment of burner
8 blinks • • • • • • • •	On	Time supervision oil preheater
9 blinks • • • • • • • • •	On	Free
10 blinks • • • • • • • • • •	Off	Wiring fault or internal fault, output contacts

During the time the cause of fault is diagnosed, the control outputs are deactivated.

- Burner remains shut down
- Fault status signal «AL» at terminal 10, according to the error code table

The diagnostics of the cause of fault is quit and the burner switched on again by resetting the burner control. Press the lockout reset button for about 1 second (< 3 seconds).

Connection diagram and internal diagram LMO14...

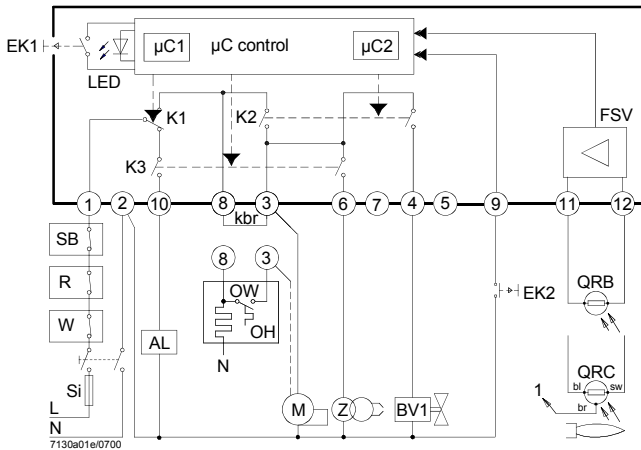

Control sequence LMO14...

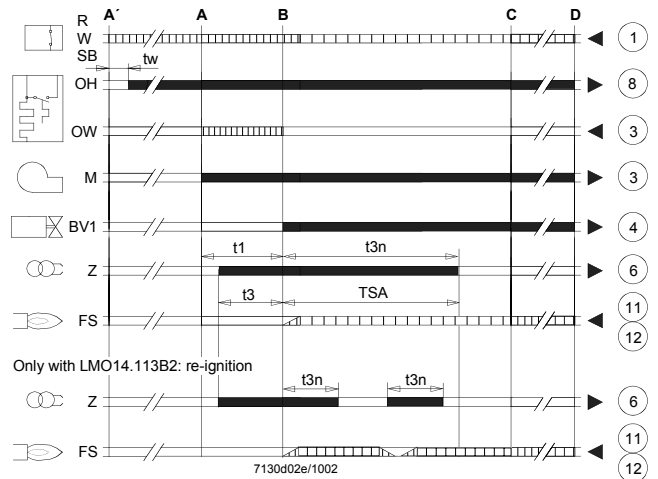

Connection diagram and internal diagram LMO24... / LMO44...

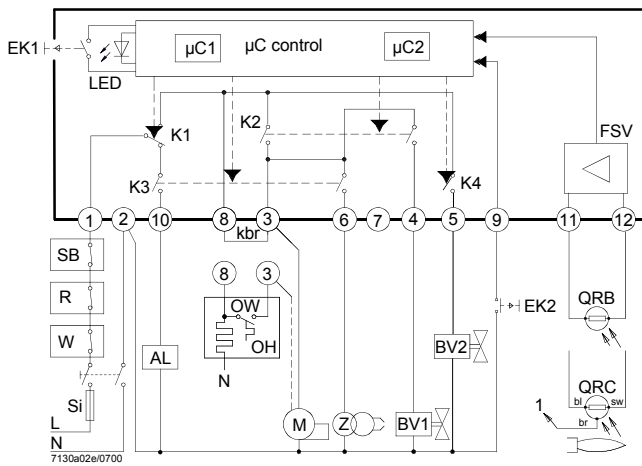

Control sequence LMO24... / LMO44...

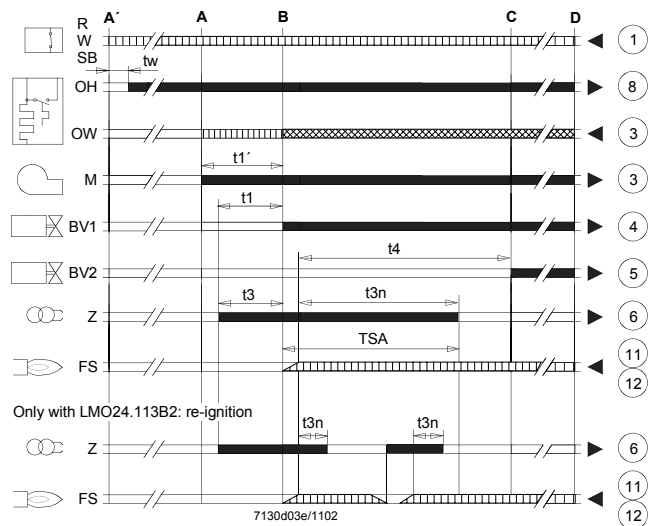

Legend

AL Alarm device
 BV... Fuel valve
 EK1 Lockout reset button
 EK2 Remote lockout reset button
 FS Flame signal
 FSV Flame signal amplifier
 K... Contacts of control relay
 kbr... Cable link (required only when no oil preheater is used)
 LED 3-color signal lamp
 M Burner motor

TSA Ignition safety time
 tw Waiting time
 t1 Pre-purge time
 t1' Purge time

A' Start of startup sequence with burners using an «OH»
 A Start of startup sequence with burners using no «OH»
 B Time of flame establishment

■ Control signals
 ▤ Required input signals
 ▨ Perm. input signals

OW Release contact of oil preheater
 OH Oil preheater
 QRB Photoresistive flame detector
 QRC Blue-flame detector
 bl = blue, br = brown, sw = black
 R Control thermostat or pressurestat
 SB Safety limit thermostat
 Si External primary fuse
 W Limit thermostat or pressure switch
 Z Ignition transformer

t3 Pre-ignition time
 t3n Post-ignition time
 t4 Interval from flame signal to release of «BV2»

C Operating position
 D Controlled shutdown by «R»

$\mu C1$ Microcontroller 1
 $\mu C2$ Microcontroller 2

Dimensions

Dimensions in mm

LMO...

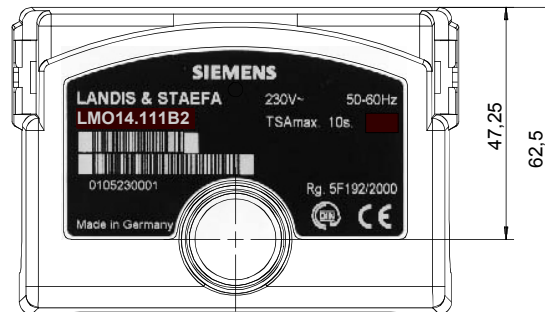
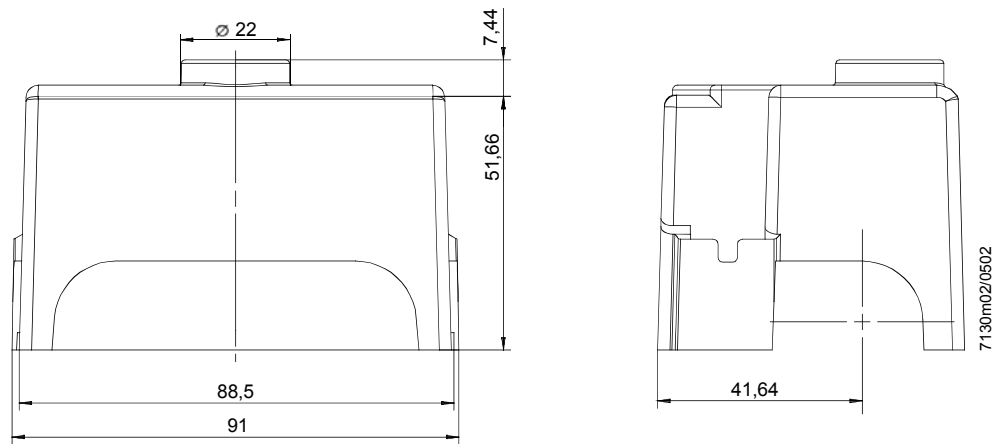

LMO... with extension of
lockout reset button
AGK20...

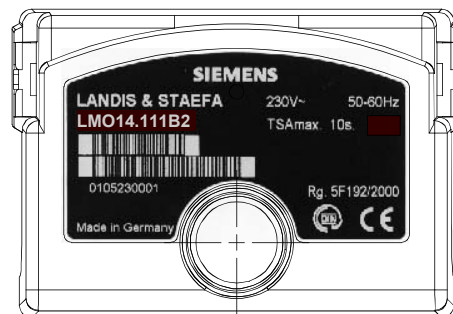
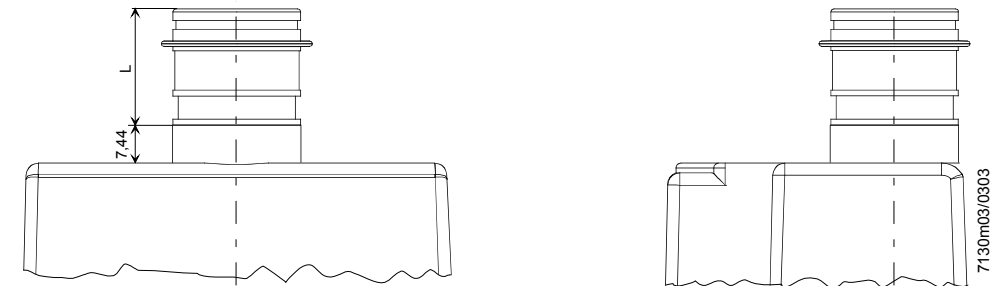

Type reference	Length «L» in mm
AGK20.20	19
AGK20.43	43
AGK20.55	55

© 2003 Siemens Building Technologies
Subject to change!